

TCAP/CRA 2012-2013



Task 3: Sarah and José Task Full Scoring Guide

Task 3. Sarah and José Task

Sarah says, "I know that I can use repeated addition to solve for multiplication even with fractions." Sarah shows her friend José what she means:

$$\frac{2}{3} \times 2 = \frac{2}{3} + \frac{2}{3} = \frac{4}{3}$$
$$\frac{3}{4} \times 3 = \frac{3}{4} + \frac{3}{4} + \frac{3}{4} = \frac{9}{4}$$

José says, "When you add fractions together you get an answer that is bigger than the fractions that you were adding, but if you multiply 2 fractions that are each less than 1 you get a fraction that is smaller than your factors." Sarah is not sure what José means. José gives an example of multiplication with 2 fractions:

$$\frac{3}{4} \times \frac{1}{2} = \frac{3}{8}$$

- a. Draw a diagram or number line to help Sarah understand José's example.



- b. Why do Sarah and José get a smaller product when they multiply two fractions that are each less than one?



3. Sarah and José Task Scoring Guide

The CCSS for Mathematical Content (2 points)

5.NF.4a The student provides a diagram or number line showing $\frac{3}{4} \times \frac{1}{2}$, or shows work _____
demonstrating an understanding that $\frac{a}{b} \times \frac{c}{d} = \frac{ac}{bd}$.

5.NF.5b The student provides an explanation for why a fraction times a fraction equals a smaller product. The explanation may include that multiplying fractions takes a portion of a portion. _____

Total Content Points _____

The CCSS for Mathematical Practice (4 points)

MP1 The student uses words, diagrams, or number lines to represent multiplication of fractions. The student responds to both parts of the task; the response in Part B does not demonstrate misconceptions. _____
(MP1: Make sense of problems and persevere in solving them.)

MP3 The student provides an argument using diagrams, number lines, or words that convinces the reader that multiplication of fractions yields a product smaller than either factor. _____
(MP3: Construct viable arguments and critique the reasoning of others.)

MP4 The student provides a diagram or number line that correctly represents multiplication of fractions. _____
(MP4: Model with mathematics.)

MP6 The student provides a diagram or number line accurately depicting $\frac{3}{4} \times \frac{1}{2} = \frac{3}{8}$; the explanation for Part B is carefully formulated. _____
(MP6: Attend to precision.)

Total Practice Points _____

Total Awarded Points _____

The CCSS for Mathematical Content Addressed in This Task

Apply and extend previous understandings of multiplication and division to multiply and divide fractions.

Apply and extend previous understandings of multiplication to multiply a fraction or whole number by a fraction.

5.NF.4a Interpret the product $(a/b) \times q$ as a parts of a partition of q into b equal parts; equivalently, as the result of a sequence of operations $a \times q \div b$. *For example, use a visual fraction model to show $(2/3) \times 4 = 8/3$, and create a story context for this equation. Do the same with $(2/3) \times (4/5) = 8/15$. (In general, $(a/b) \times (c/d) = ac/bd$.)*

Interpret multiplication as scaling (resizing), by:

5.NF.5b Explaining why multiplying a given number by a fraction greater than 1 results in a product greater than the given number (recognizing multiplication by whole numbers greater than 1 as a familiar case); explaining why multiplying a given number by a fraction less than 1 results in a product smaller than the given number; and relating the principle of fraction equivalence $a/b = (n \times a)/(n \times b)$ to the effect of multiplying a/b by 1.

The CCSS for Mathematical Practice*

1. Make sense of problems and persevere in solving them.
2. Reason abstractly and quantitatively.
3. Construct viable arguments and critique the reasoning of others.
4. Model with mathematics.
5. Use appropriate tools strategically.
6. Attend to precision.
7. Look for and make use of structure.
8. Look for and express regularity in repeated reasoning.

*Gray text indicates Mathematical Practices that are not addressed in this task.

Students' responses to a mathematical task provide evidence of what they understand and are able to do in relation to the standards and practices. Across tasks, this cumulative evidence shows students' understanding and abilities within a domain. When students do not respond completely to all parts of a task, they provide insufficient evidence of their mathematical understanding and abilities and therefore do not fully demonstrate the expectations of the standards and practices aligned with that task.

Task 3. Sarah and José Task

Sarah says, "I know that I can use repeated addition to solve for multiplication even with fractions." Sarah shows her friend José what she means:

$$\frac{2}{3} \times 2 = \frac{2}{3} + \frac{2}{3} = \frac{4}{3}$$

$$\frac{3}{4} \times 3 = \frac{3}{4} + \frac{3}{4} + \frac{3}{4} = \frac{9}{4}$$

José says, "When you add fractions together you get an answer that is bigger than the fractions that you were adding, but if you multiply 2 fractions that are each less than 1 you get a fraction that is smaller than your factors." Sarah is not sure what José means. José gives an example of multiplication with 2 fractions:

$$\frac{3}{4} \times \frac{1}{2} = \frac{3}{8}$$

- a. Draw a diagram or number line to help Sarah understand José's example.

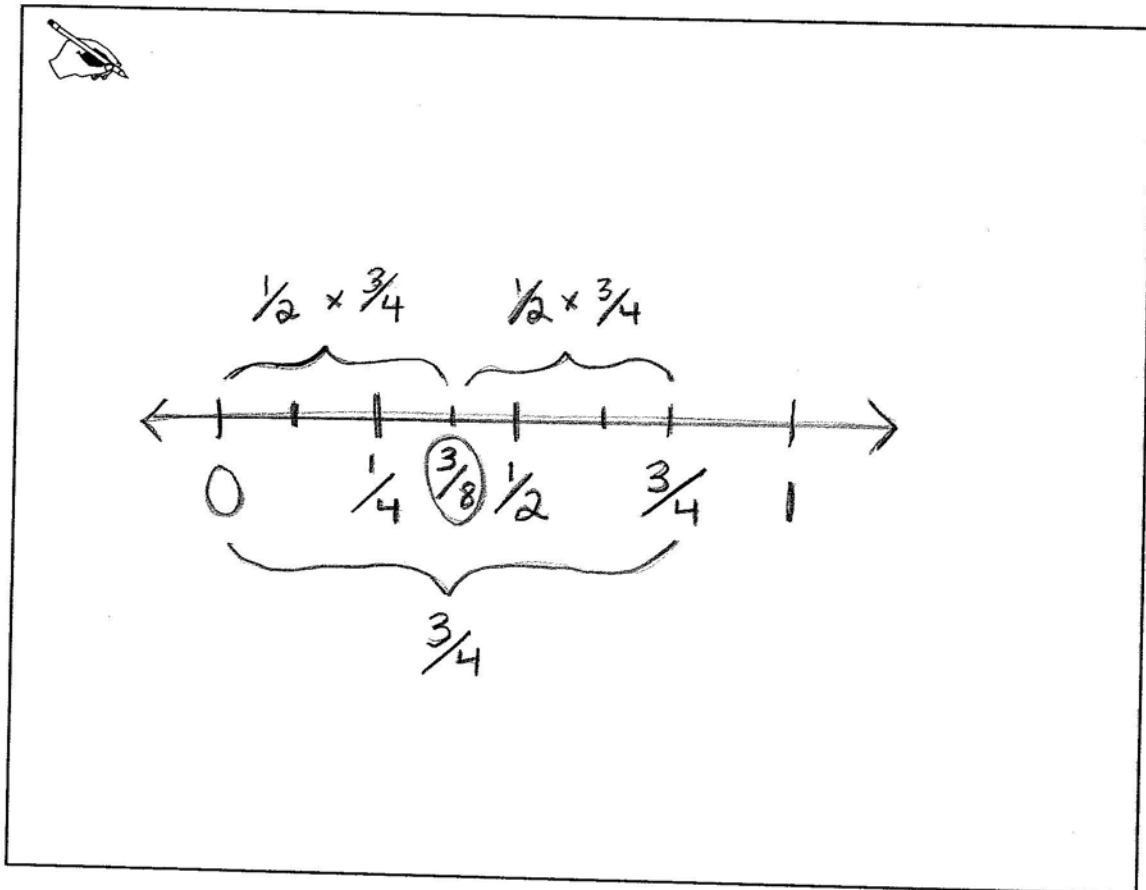

- b. Why do Sarah and José get a smaller product when they multiply two fractions that are each less than one?



The first fraction is less than 1. Multiplying by another fraction less than 1 means taking a part of the first fraction, which is a smaller product.

Guide 1

Litho 11233

Total Content Points: 2 (5.NF.4a, 5.NF.5b)

Total Practice Points: 4 (MP1, MP3, MP4, MP6)

In Part A, the student provides a number line showing $\frac{3}{4} \times \frac{1}{2} = \frac{3}{8}$, which is a model representing that multiplication of fractions less than one yields a product smaller than either factor (5.NF.4a, MP4). In Part B, the student provides a viable argument in words explaining why a fraction times a fraction equals a smaller product ("Multiplying by another fraction less than 1 means taking a part of the first fraction") (5.NF.5b, MP3).

The student provides both an accurate number line depicting $\frac{3}{4} \times \frac{1}{2} = \frac{3}{8}$ and a carefully formulated explanation (MP6), thereby responding reasonably to both parts of the task (MP1).

Total Awarded Points: 6 out of 6

Task 3. Sarah and José Task

Sarah says, "I know that I can use repeated addition to solve for multiplication even with fractions." Sarah shows her friend José what she means:

$$\frac{2}{3} \times 2 = \frac{2}{3} + \frac{2}{3} = \frac{4}{3}$$

$$\frac{3}{4} \times 3 = \frac{3}{4} + \frac{3}{4} + \frac{3}{4} = \frac{9}{4}$$

José says, "When you add fractions together you get an answer that is bigger than the fractions that you were adding, but if you multiply 2 fractions that are each less than 1 you get a fraction that is smaller than your factors." Sarah is not sure what José means. José gives an example of multiplication with 2 fractions:

$$\frac{3}{4} \times \frac{1}{2} = \frac{3}{8}$$

- a. Draw a diagram or number line to help Sarah understand José's example.

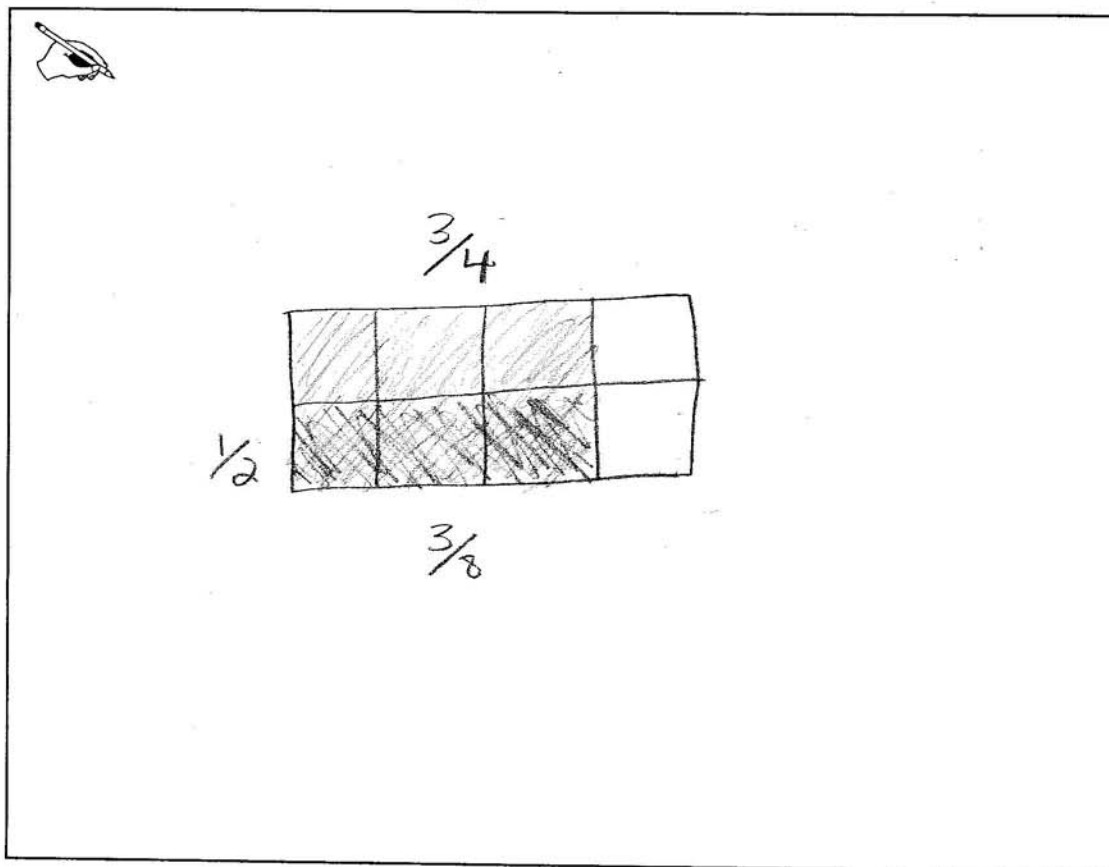

- b. Why do Sarah and José get a smaller product when they multiply two fractions that are each less than one?



You aren't multiplying either fraction by a number 1 or bigger, so both fractions get smaller for the product.

Guide 2

Litho 11195

Total Content Points: 1 (5.NF.4a)

Total Practice Points: 3 (MP1, MP3, MP4)

The student provides a diagram showing $\frac{3}{4} \times \frac{1}{2} = \frac{3}{8}$ (5.NF.4a), which is a model that represents multiplication of fractions (MP4). Furthermore, the diagram provides a convincing argument that multiplication of fractions yields a product ($\frac{3}{8}$) smaller than either factor ($\frac{3}{4}$, $\frac{1}{2}$) (MP3). In Part B, the student's explanation of why a fraction times a fraction equals a smaller product ("You aren't multiplying either fraction by a number 1 or bigger, so both fractions get smaller for the product") does not explain why the product is smaller and therefore is not carefully formulated (no credit for 5.NF.5b, no credit for MP6). The student responds to both parts of the task by using a diagram to represent multiplication of fractions in Part A and by providing an explanation in Part B that, while unacceptable for a content point, does not demonstrate any misconceptions (MP1).

Total Awarded Points: 4 out of 6

Task 3. Sarah and José Task

Sarah says, "I know that I can use repeated addition to solve for multiplication even with fractions." Sarah shows her friend José what she means:

$$\frac{2}{3} \times 2 = \frac{2}{3} + \frac{2}{3} = \frac{4}{3}$$

$$\frac{3}{4} \times 3 = \frac{3}{4} + \frac{3}{4} + \frac{3}{4} = \frac{9}{4}$$

José says, "When you add fractions together you get an answer that is bigger than the fractions that you were adding, but if you multiply 2 fractions that are each less than 1 you get a fraction that is smaller than your factors." Sarah is not sure what José means. José gives an example of multiplication with 2 fractions:

$$\frac{3}{4} \times \frac{1}{2} = \frac{3}{8}$$

- a. Draw a diagram or number line to help Sarah understand José's example.

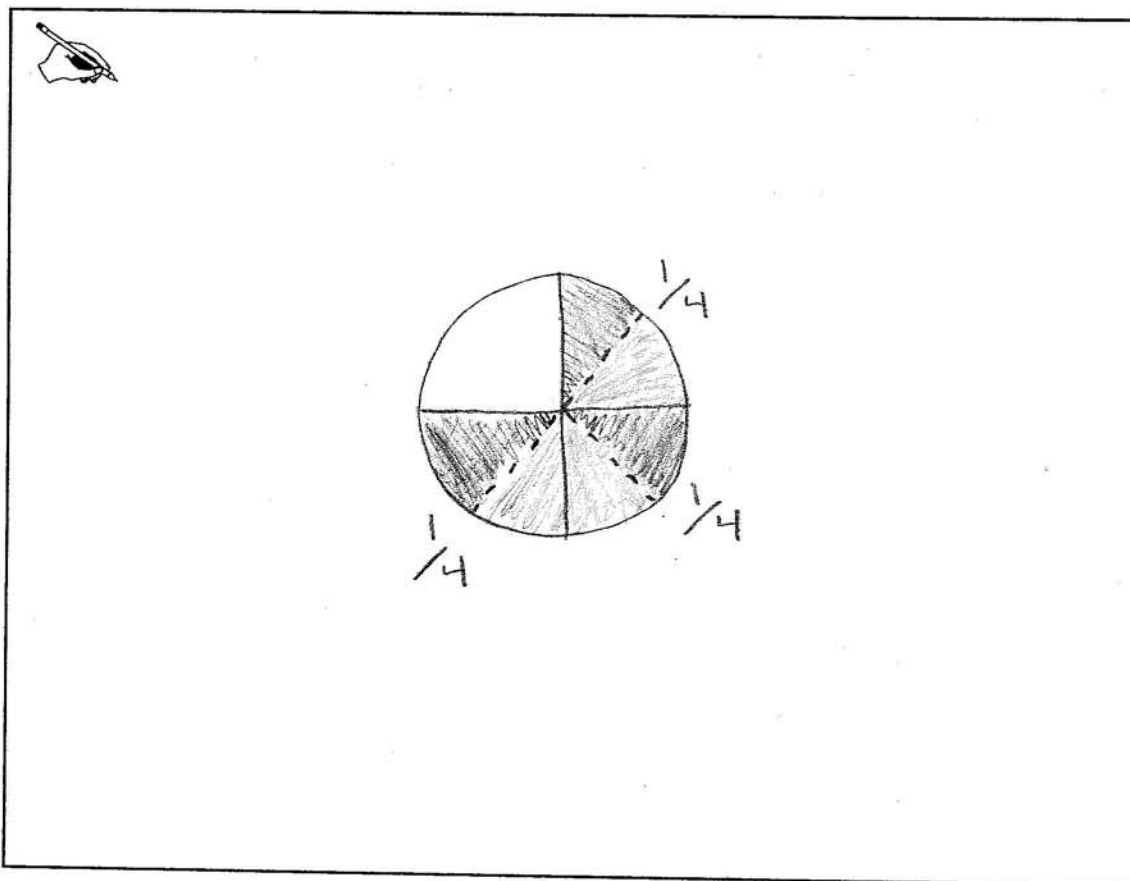

- b. Why do Sarah and José get a smaller product when they multiply two fractions that are each less than one?



Both fractions are less than a whole, so the answer is less than a whole, too.

Guide 3

Litho 11228

Total Content Points: 1 (5.NF.4a)

Total Practice Points: 2 (MP1, MP4)

In Part A, the student provides a diagram that shows $\frac{3}{4} \times \frac{1}{2}$ (by shading in one-half of each of the three quarter-circle segments) and that represents the multiplication of fractions yielding a product smaller than either factor (5.NF.4a, MP4). The student's explanation for why a fraction multiplied by a fraction equals a smaller product is neither an acceptable response nor a convincing argument (no credit for 5.NF.5b, no credit for MP3). The explanation in Part B is not carefully formulated, and it demonstrates a lack of precision (no credit for MP6). The student responds to both parts of the task by using a diagram to represent the multiplication of fractions in Part A and by providing an explanation in Part B that, while unacceptable for a content point, does not indicate any misconceptions (MP1).

Total Awarded Points: 3 out of 6

Task 3. Sarah and José Task

Sarah says, "I know that I can use repeated addition to solve for multiplication even with fractions." Sarah shows her friend José what she means:

$$\frac{2}{3} \times 2 = \frac{2}{3} + \frac{2}{3} = \frac{4}{3}$$

$$\frac{3}{4} \times 3 = \frac{3}{4} + \frac{3}{4} + \frac{3}{4} = \frac{9}{4}$$

José says, "When you add fractions together you get an answer that is bigger than the fractions that you were adding, but if you multiply 2 fractions that are each less than 1 you get a fraction that is smaller than your factors." Sarah is not sure what José means. José gives an example of multiplication with 2 fractions:

$$\frac{3}{4} \times \frac{1}{2} = \frac{3}{8}$$

- a. Draw a diagram or number line to help Sarah understand José's example.

Key:

[rectangle with diagonal lines] $\frac{3}{4}$

[rectangle with diagonal lines] $\frac{1}{2}$

- b. Why do Sarah and José get a smaller product when they multiply two fractions that are each less than one?



Multiplying a fraction by a fraction is like taking part of a part. Taking $\frac{1}{2}$ of $\frac{3}{4}$ means the product is less than $\frac{3}{4}$. Taking $\frac{3}{4}$ of $\frac{1}{2}$ means the product is less than $\frac{1}{2}$.

Guide 4

Litho 11192

Total Content Points: 1 (5.NF.5b)

Total Practice Points: 1 (MP3)

The student's diagram in Part A showing $\frac{3}{4} \times \frac{1}{2}$ is incorrect (no credit for 5.NF.4a), and it does not correctly model multiplication of fractions (no credit for MP4). The student's explanation in Part B ("Multiplying a fraction by a fraction is like taking part of a part...") correctly indicates that when multiplying fractions, you are taking a portion of a portion (5.NF.5b), and provides a convincing argument that multiplication of fractions yields a product that is smaller than either factor (MP3). Although the student responds to both parts of the task, the inaccurate diagram indicates both a lack of making sense of the problem and a lack of precision (no credit for MP1, no credit for MP6).

Total Awarded Points: 2 out of 6

Task 3. Sarah and José Task

Sarah says, "I know that I can use repeated addition to solve for multiplication even with fractions." Sarah shows her friend José what she means:

$$\frac{2}{3} \times 2 = \frac{2}{3} + \frac{2}{3} = \frac{4}{3}$$

$$\frac{3}{4} \times 3 = \frac{3}{4} + \frac{3}{4} + \frac{3}{4} = \frac{9}{4}$$

José says, "When you add fractions together you get an answer that is bigger than the fractions that you were adding, but if you multiply 2 fractions that are each less than 1 you get a fraction that is smaller than your factors." Sarah is not sure what José means. José gives an example of multiplication with 2 fractions:

$$\frac{3}{4} \times \frac{1}{2} = \frac{3}{8}$$

- a. Draw a diagram or number line to help Sarah understand José's example.

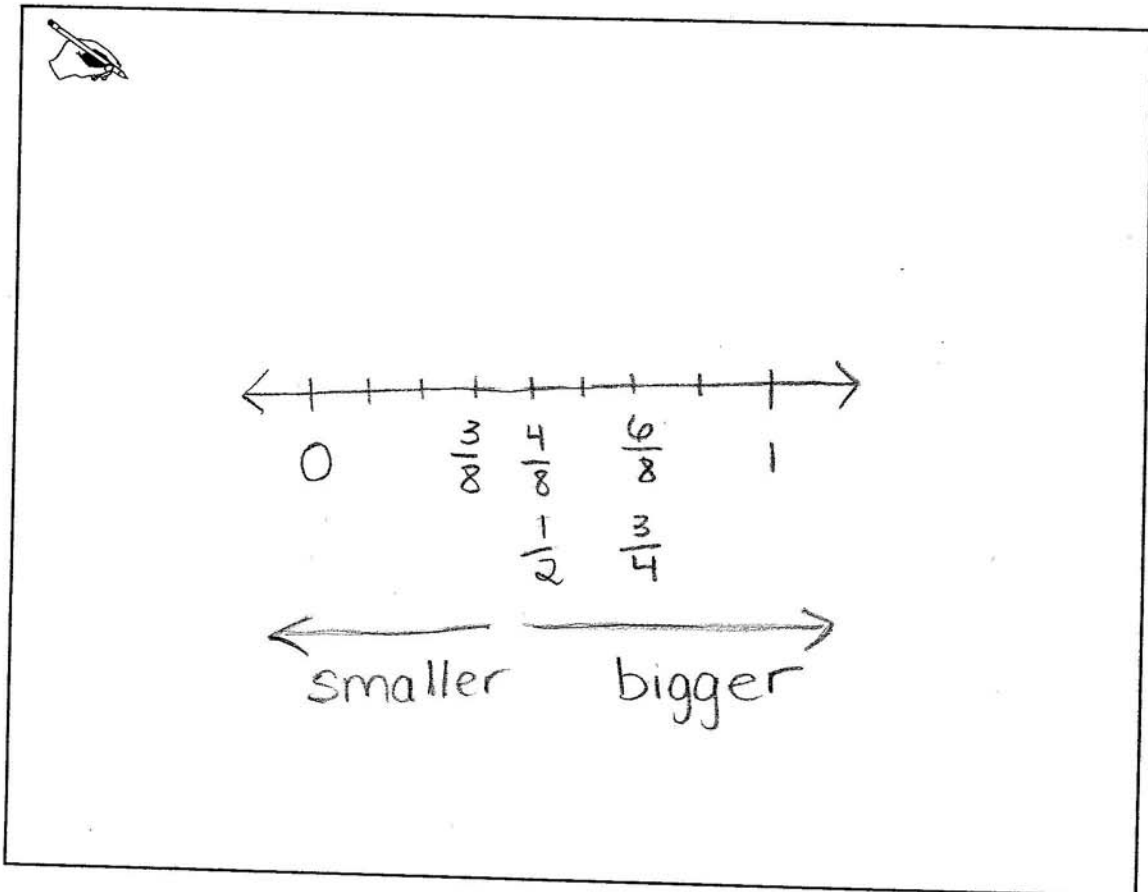

- b. Why do Sarah and José get a smaller product when they multiply two fractions that are each less than one?



When you multiply by $\frac{1}{2}$,
you are taking a part
of the fraction $\frac{3}{4}$, so
the product is less
than $\frac{3}{4}$.

Guide 5

Litho 11205

Total Content Points: 1 (5.NF.5b)

Total Practice Points: 1 (MP3)

In Part A, the student's number line does not clearly model $\frac{3}{4} \times \frac{1}{2}$ and therefore does not correctly represent multiplication of fractions yielding a smaller product (no credit for 5.NF.4a, no credit for MP4). The student's written explanation in Part B correctly indicates that multiplying fractions means taking a portion of a portion (5.NF.5b). The number line in Part A showing $\frac{3}{8}$ as "smaller" and $\frac{3}{4}$ and $\frac{1}{2}$ as "bigger" and the explanation in Part B both provide a convincing argument that multiplication of fractions yields a product smaller than either factor (MP3). Although the student responds to both parts of the task, the number line in Part A does not clearly represent $\frac{3}{4} \times \frac{1}{2}$ (no credit for MP1), thereby indicating a lack of precision (no credit for MP6).

Total Awarded Points: 2 out of 6

Task 3. Sarah and José Task

Sarah says, "I know that I can use repeated addition to solve for multiplication even with fractions." Sarah shows her friend José what she means:

$$\frac{2}{3} \times 2 = \frac{2}{3} + \frac{2}{3} = \frac{4}{3}$$

$$\frac{3}{4} \times 3 = \frac{3}{4} + \frac{3}{4} + \frac{3}{4} = \frac{9}{4}$$

José says, "When you add fractions together you get an answer that is bigger than the fractions that you were adding, but if you multiply 2 fractions that are each less than 1 you get a fraction that is smaller than your factors." Sarah is not sure what José means. José gives an example of multiplication with 2 fractions:

$$\frac{3}{4} \times \frac{1}{2} = \frac{3}{8}$$

- a. Draw a diagram or number line to help Sarah understand José's example.

3 - NOT WHAT I

8 - TOTAL PIECES

- b. Why do Sarah and José get a smaller product when they multiply two fractions that are each less than one?

 They get a different and smaller product because:

Sarah: $\frac{2}{3} \times 2 = \frac{2}{3} + \frac{2}{3} = \frac{4}{3} = 1\frac{1}{3}$

$2+2=4$

Why the same?

José:

$3 \times 1 = 3$

=

$\frac{3}{8}$

$4 \times 2 = 8$

Guide 6

Litho 10430

Total Content Points: 1 (5.NF.4a)

Total Practice Points: 0

In Part A, the student's diagrams do not adequately show $\frac{3}{4} \times \frac{1}{2}$, nor do they correctly represent multiplication of fractions (no credit for MP4). However, in Part B the student provides work ($\frac{3}{4} \times \frac{1}{2} = \frac{3}{8}$) demonstrating an understanding that $\frac{a}{b} \times \frac{c}{d} = \frac{ac}{bd}$ (5.NF.4a).

None of the student's work in Part B provides a sufficient explanation for why a fraction less than one multiplied by a fraction less than one equals a smaller product (no credit for 5.NF.5b). Therefore, the student does not provide a convincing argument for this multiplication fact (no credit for MP3). The student does not provide a diagram

accurately depicting $\frac{3}{4} \times \frac{1}{2} = \frac{3}{8}$ in Part A and does not provide a carefully formulated argument in Part B (no credit for MP6), thereby not fully making sense of or completing the task (no credit for MP1).

Total Awarded Points: 1 out of 6

Task 3. Sarah and José Task

Sarah says, "I know that I can use repeated addition to solve for multiplication even with fractions." Sarah shows her friend José what she means:

$$\frac{2}{3} \times 2 = \frac{2}{3} + \frac{2}{3} = \frac{4}{3}$$

$$\frac{3}{4} \times 3 = \frac{3}{4} + \frac{3}{4} + \frac{3}{4} = \frac{9}{4}$$

José says, "When you add fractions together you get an answer that is bigger than the fractions that you were adding, but if you multiply 2 fractions that are each less than 1 you get a fraction that is smaller than your factors." Sarah is not sure what José means. José gives an example of multiplication with 2 fractions:

$$\frac{3}{4} \times \frac{1}{2} = \frac{3}{8}$$

- a. Draw a diagram or number line to help Sarah understand José's example.

Handwritten student work showing a diagram of a rectangle divided into 8 equal parts, with 3 parts shaded. The student has written "3 x 2 = 8" and "you multiply 4x2". Below the diagram, the student has written "you will get 8, then you multiply 3x1 you will get 3, then make a fraction (3/8)".

- b. Why do Sarah and José get a smaller product when they multiply two fractions that are each less than one?

 Because they simply, and got a smaller product.

Guide 7

Litho 10334

Total Content Points: 1 (5.NF.4a)

Total Practice Points: 0

In Part A, the student shows work demonstrating that $\frac{a}{b} \times \frac{c}{d} = \frac{ac}{bd}$ (5.NF.4a), but

provides no diagram or number line that correctly represents multiplication of fractions (no credit for MP4). The student's explanation in Part B is neither an adequate explanation nor a convincing argument for why multiplying fractions less than one equals a smaller product than either factor (no credit for 5.NF.5b, no credit for MP3). The student does not adequately represent multiplication of fractions in Part A and does not provide an acceptable explanation for why a fraction times a fraction equals a smaller product in Part B (no credit for MP1, no credit for MP6).

Total Awarded Points: 1 out of 6

Task 3. Sarah and José Task

Sarah says, "I know that I can use repeated addition to solve for multiplication even with fractions." Sarah shows her friend José what she means:

$$\frac{2}{3} \times 2 = \frac{2}{3} + \frac{2}{3} = \frac{4}{3}$$

$$\frac{3}{4} \times 3 = \frac{3}{4} + \frac{3}{4} + \frac{3}{4} = \frac{9}{4}$$

José says, "When you add fractions together you get an answer that is bigger than the fractions that you were adding, but if you multiply 2 fractions that are each less than 1 you get a fraction that is smaller than your factors." Sarah is not sure what José means. José gives an example of multiplication with 2 fractions:

$$\frac{3}{4} \times \frac{1}{2} = \frac{3}{8}$$

- a. Draw a diagram or number line to help Sarah understand José's example.

$\frac{3}{4} \times \frac{1}{2}$
 $3 \times 1 = 3$
 $4 \times 2 = 8$
 $\frac{3}{8}$
 3 to $\frac{3}{2}$ you add 3 ① time
 $4 + 4 = 8$ you add 4 ② times
 then you put the fraction line between the 3 and the 8 and get $\frac{3}{8}$

- b. Why do Sarah and José get a smaller product when they multiply two fractions that are each less than one?

 then must get multiplied by a whole or they will get smaller because fractions are not a whole number.

Guide 8

Litho 10332

Total Content Points: 1 (5.NF.4a)

Total Practice Points: 0

In Part A, the student shows work demonstrating an understanding that $\frac{a}{b} \times \frac{c}{d} = \frac{ac}{bd}$ (5.NF.4a), but provides no diagram or number line that correctly represents multiplication of fractions (no credit for MP4). In Part B, the student's explanation is neither an acceptable explanation for why a fraction times a fraction equals a smaller product than either factor (no credit for 5.NF.5b), nor a convincing argument (no credit for MP3). The student does not adequately represent multiplication of fractions in Part A and does not provide an acceptable explanation in Part B for why a fraction times a fraction equals a smaller product (no credit for MP1, no credit for MP6).

Total Awarded Points: 1 out of 6

Task 3. Sarah and José Task

Sarah says, "I know that I can use repeated addition to solve for multiplication even with fractions." Sarah shows her friend José what she means:

$$\frac{2}{3} \times 2 = \frac{2}{3} + \frac{2}{3} = \frac{4}{3}$$

$$\frac{3}{4} \times 3 = \frac{3}{4} + \frac{3}{4} + \frac{3}{4} = \frac{9}{4}$$

José says, "When you add fractions together you get an answer that is bigger than the fractions that you were adding, but if you multiply 2 fractions that are each less than 1 you get a fraction that is smaller than your factors." Sarah is not sure what José means. José gives an example of multiplication with 2 fractions:

$$\frac{3}{4} \times \frac{1}{2} = \frac{3}{8}$$

- a. Draw a diagram or number line to help Sarah understand José's example.

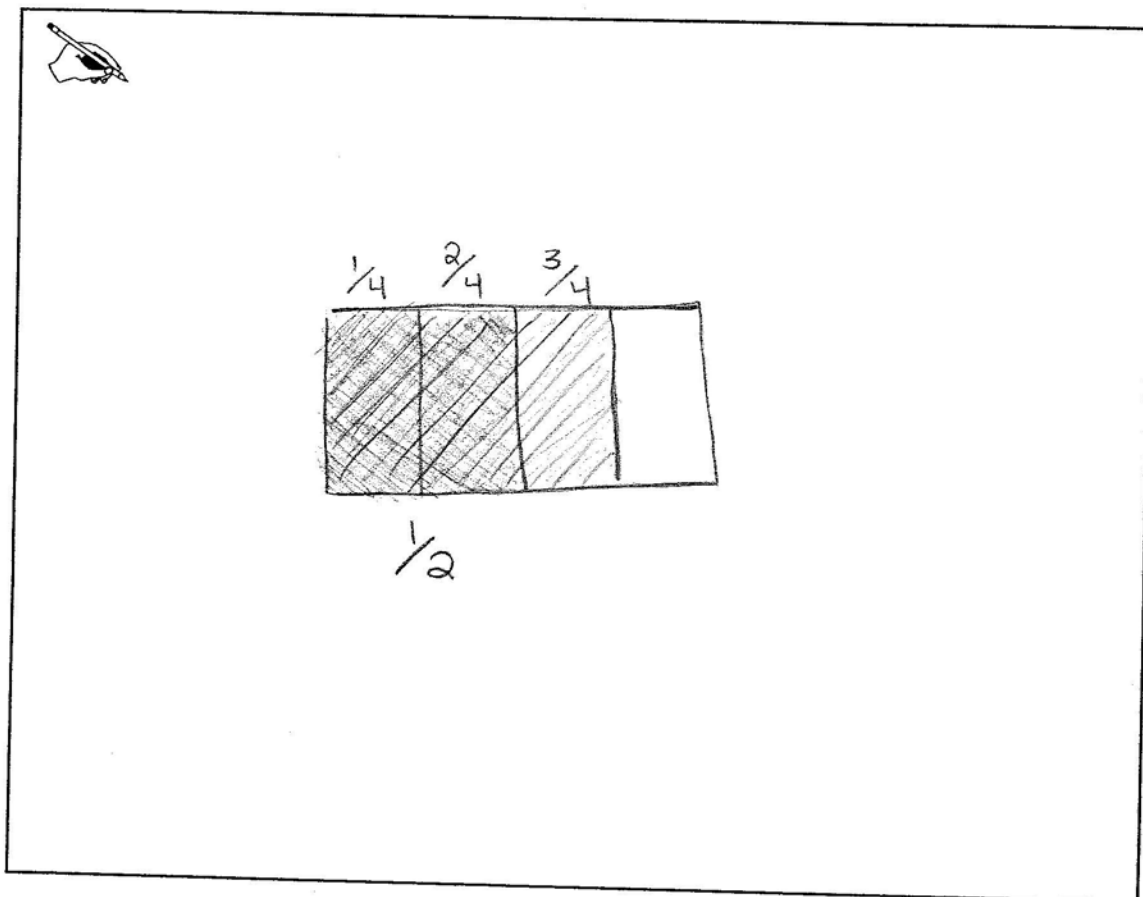

- b. Why do Sarah and José get a smaller product when they multiply two fractions that are each less than one?



You multiply the numerators and denominators. When you multiply the denominators, the number gets bigger. A bigger denominator means smaller pieces of the whole. When you multiply the numerators, the number stays the same, but that means the number of pieces.

Total Content Points: 0

Total Practice Points: 0

In Part A, the student's diagram showing $\frac{3}{4} \times \frac{1}{2}$ is incorrect and does not correctly represent multiplication of fractions (no credit for 5.NF.4a, no credit for MP4). In Part B, the student's explanation ("...When you multiply the denominators, the number gets bigger. A bigger denominator means smaller pieces of the whole...") does not relate "smaller pieces" to a smaller product and does not make a convincing argument that multiplication of fractions yields a product smaller than either factor (no credit for 5.NF.5b, no credit for MP3). The student provides neither an accurate diagram in Part A nor a correct explanation in Part B (no credit for MP1, no credit for MP6).

Total Awarded Points: 0 out of 6

Task 3. Sarah and José Task

Sarah says, "I know that I can use repeated addition to solve for multiplication even with fractions." Sarah shows her friend José what she means:

$$\frac{2}{3} \times 2 = \frac{2}{3} + \frac{2}{3} = \frac{4}{3}$$

$$\frac{3}{4} \times 3 = \frac{3}{4} + \frac{3}{4} + \frac{3}{4} = \frac{9}{4}$$

José says, "When you add fractions together you get an answer that is bigger than the fractions that you were adding, but if you multiply 2 fractions that are each less than 1 you get a fraction that is smaller than your factors." Sarah is not sure what José means. José gives an example of multiplication with 2 fractions:

$$\frac{3}{4} \times \frac{1}{2} = \frac{3}{8}$$

- a. Draw a diagram or number line to help Sarah understand José's example.

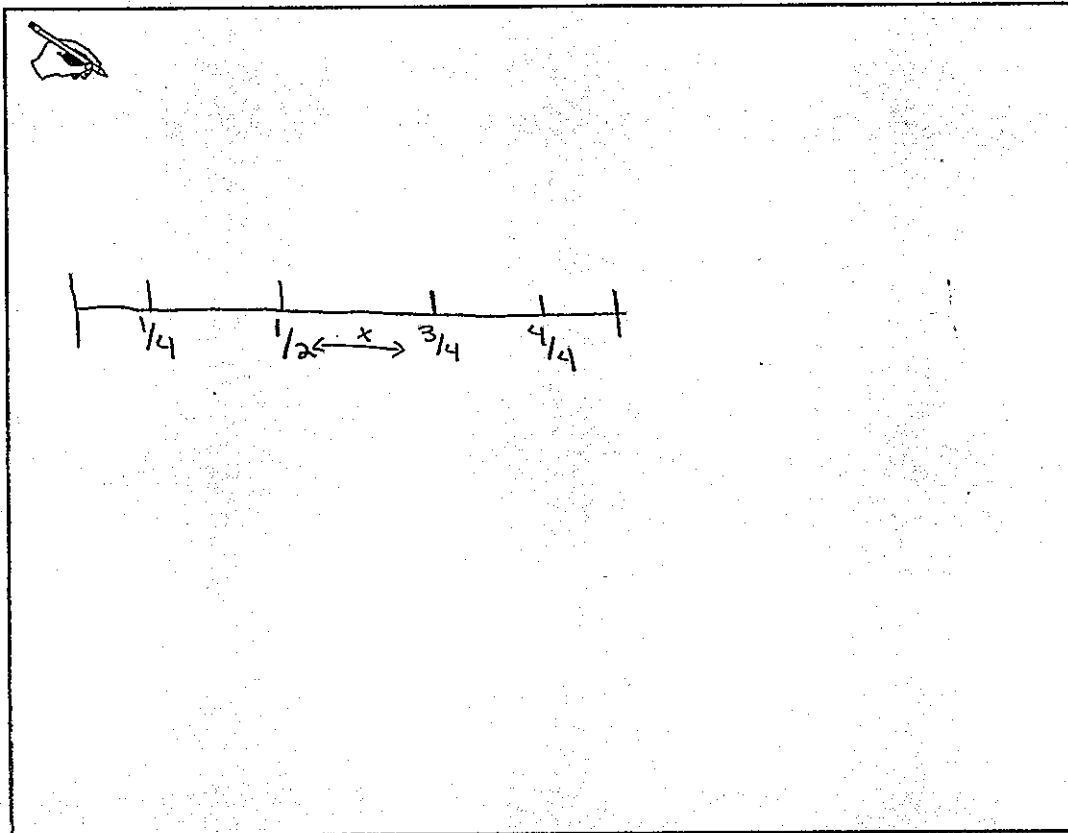

- b. Why do Sarah and José get a smaller product when they multiply two fractions that are each less than one?

 They get a smaller product because multiplying fractions is just like dividing whole numbers.

Total Content Points: 0

Total Practice Points: 0

In Part A, the student's number line showing $\frac{3}{4} \times \frac{1}{2}$ is incorrect and does not accurately represent multiplication of fractions (no credit for 5.NF.4a, no credit for MP4). In Part B, the student's explanation for why a fraction times a fraction equals a smaller product than the factors shows partial understanding, but is incomplete and unclear (no credit for 5.NF.5b). The lack of a full explanation in Part B results in an incomplete argument that is not carefully formulated (no credit for MP3, no credit for MP6). The response in Part A is incorrect, and the response in Part B is incomplete (no credit for MP1).

Total Awarded Points: 0